

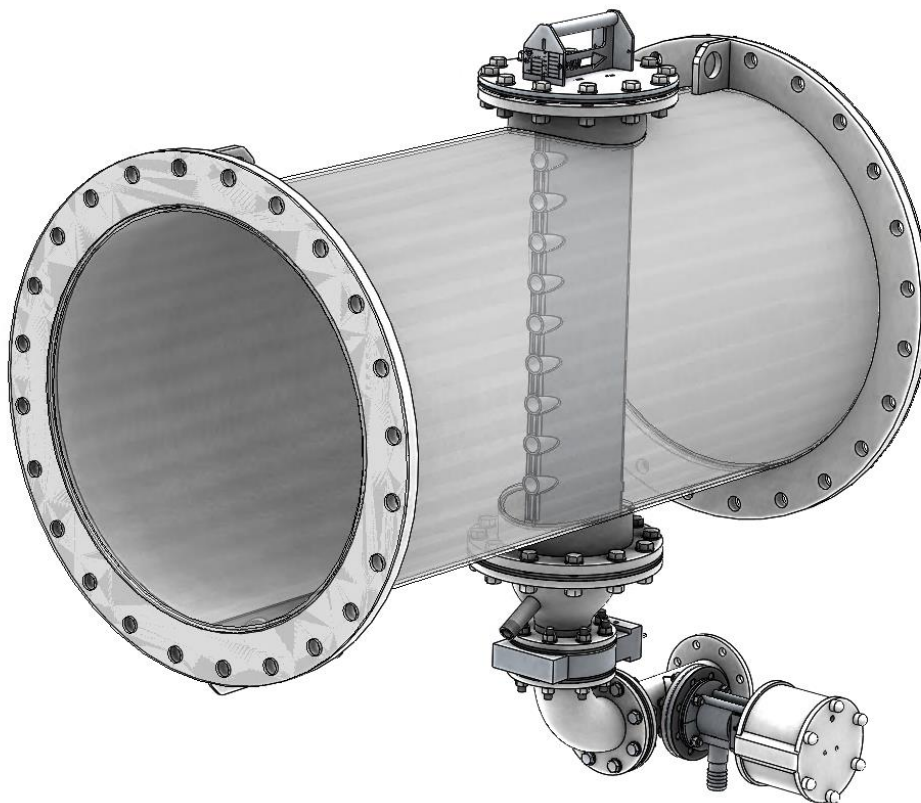

Introduction

The Gravity Sampler Assembly, or GSA, is designed to take a process control sample from a gravity, or non-pumped, process line or launder. It utilises the well-known technique of sampling via a static cutter. A GSA is recommended for all gravity line applications in order to improve sample representivity.



GSA with reducing cutter and a poppet sampler to produce a composite sample.

Application

The GSA is used as a primary sampler to produce a continuous sample for an On Stream Analyser, OSA. In conjunction with a poppet sampler, as a secondary sampler it can produce a composite or shift sample. It can also be engineered to produce both a continuous sample as well as composite sample.

Features

GSA samplers feature a removable cutter which has a tungsten carbide hardened face to increase wear life. The maintenance friendly design allows for replacing the cutter without having to remove any pipes or large hatches. The reducing cutter design reduces produced sample from the large process lines, in order to match the OSA requirements.

Advanced Design

The GSA has designed using Computational Fluid Dynamics (CFD) to analyse internal flow path in order to improve sample representivity from the static cutter. The cutter has been designed to reduce pressure drop to a minimum.

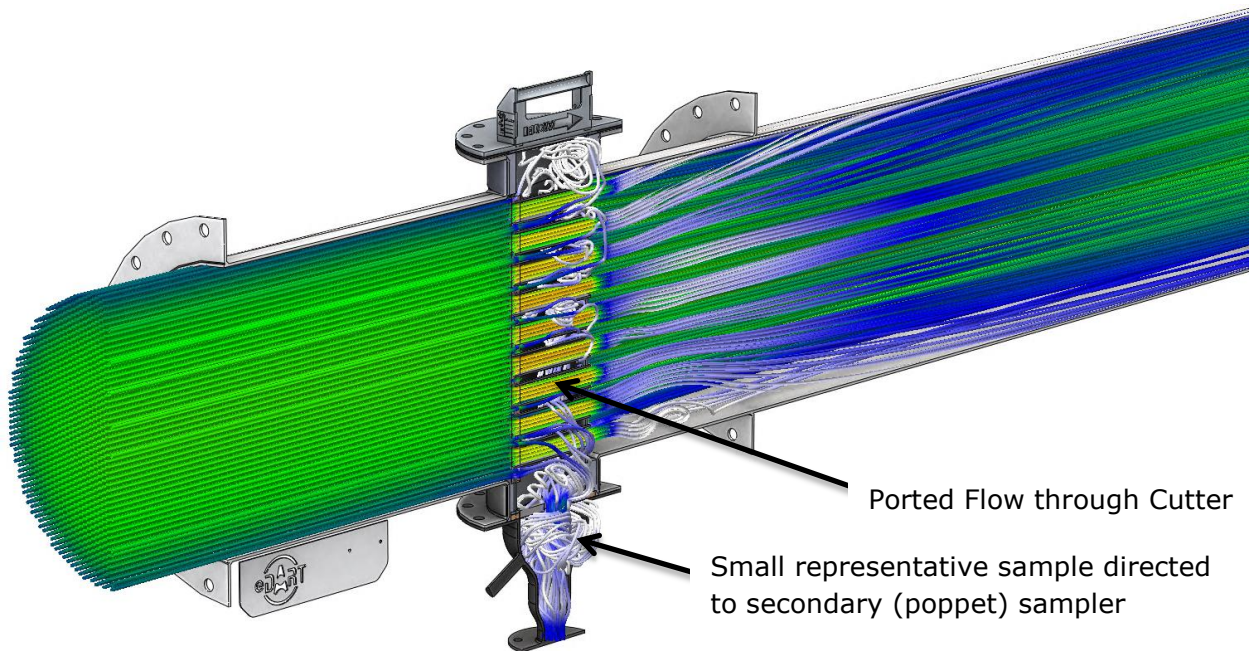

The cutter design promotes flow recovery downstream of the cutter.

